



臺灣杉毅事業有限公司

TAIWAN SANEAST ENTERPRISE, INC.

# GBS-H Series High Temperature Blender

## Features :

- $\pm 0.1\%$  Accuracy (No noise, vibration)
- Positive displacement reverse auger mixing gives superior uniform and no separation.
- Touch panel console.
- The load cell is overload protected and provides measurement accuracy independent of temperature change..
- Retains heat inside the blender and resists moisture contamination.
- Operates down-stream of conventional dryers and allows high accuracy blending of dried materials at temperatures up to 170C.
- Incorporates up to 6 components. 2 slide fed and 4 auger fed depending on model.



GBS-H-200-2

Head Office : No.207, Wu Gu Wang N.  
St., San Chung City 241 Taipei Hsien, Taiwan

TEL : 886-2-8511-0898

FAX : 886-2-8511-0359

<http://www.tsaneast.com.tw>

E-mail : [tsaneast@ms5.hinet.net](mailto:tsaneast@ms5.hinet.net)



# 臺灣杉毅事業有限公司

TAIWAN SANEAST ENTERPRISE, INC.

## Specifications :

Model	GBS-H-050	GBS-H-200	GBS-H-400	GBS-H-800	GBS-H-1000	GBS-H-2000
Capacity (KG/HR)	50	200	400	800	1000	2000
Components	2,3,4	2,3,4	2,3,4	2,3,4,5,6	2,3,4,5,6	2,3,4,5,6
Material temperature	170	170	170	170	170	170
H (mm)	1400	1980	2035	2430	2800	3300
W1 (mm)	900	900	900	1000	1200	1200
W2 (mm)	900	900	1200	1600	1600	1600
D (mm)	900	900	900	1000	1200	1200
Weight (KG)	250	285	300	350	385	450

### Remarks :

1. Standard Power supply is 220V/3P/60Hz. If other specifications required, please advice before order.
2. Vibration, Noise, Dryer air flow, Compressed air or N<sub>2</sub> pressure, will influence dosing accuracy.

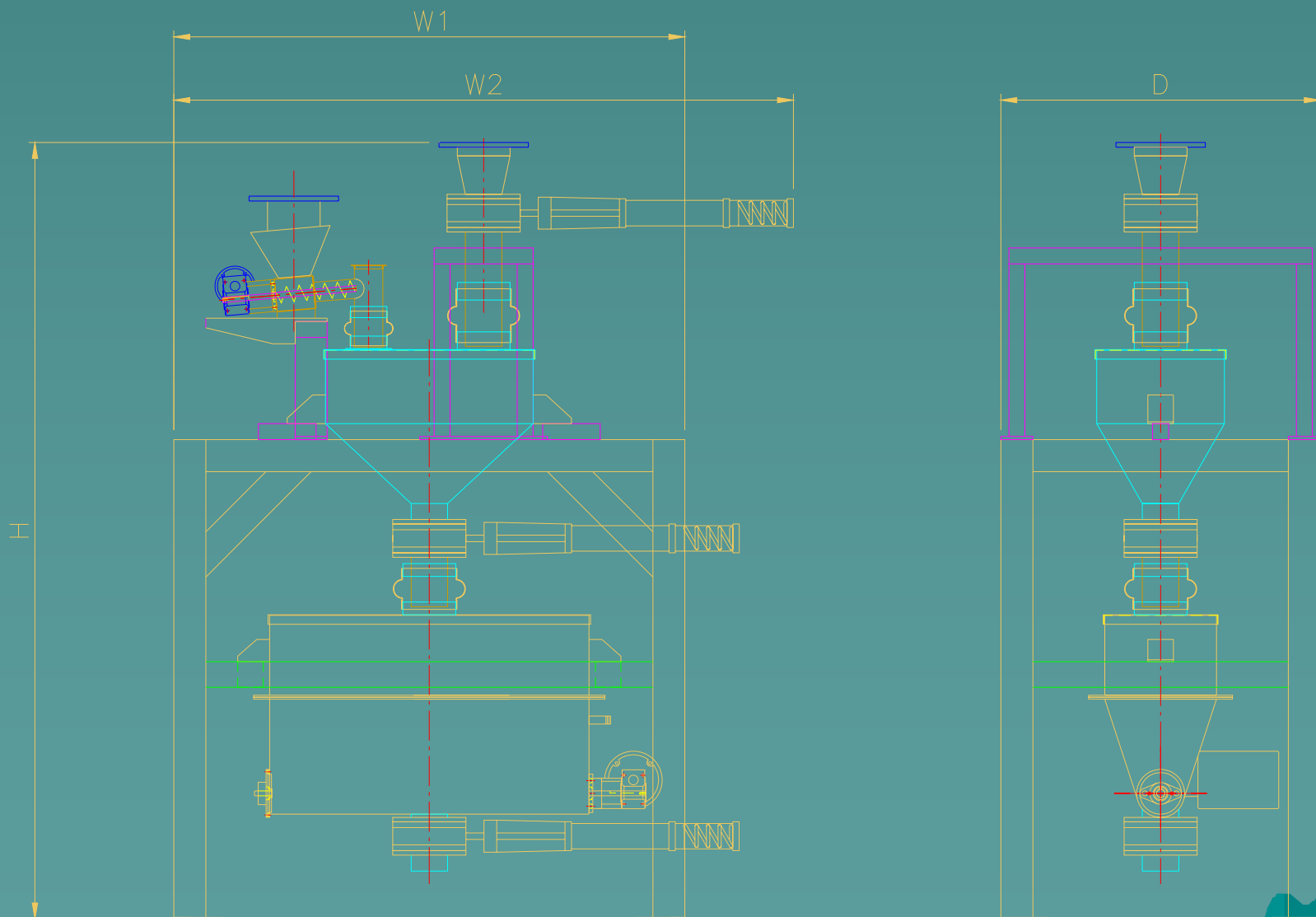

Head Office : No.207, Wu Gu Wang N.  
St., San Chung City 241 Taipei Hsien, Taiwan

TEL : 886-2-8511-0898

FAX : 886-2-8511-0359

<http://www.tsaneast.com.tw>

E-mail : [tsaneast@ms5.hinet.net](mailto:tsaneast@ms5.hinet.net)